

DIMPLEX THERMAL SOLUTIONS GO2-2-10000-PW-OSP-40-105-454B-IN

Technical Details

- Cooling Capacity: 341,200 btu/hr
- Refrigerant: R454B (GWP: 466 AR4)
- Supply Temperature: 40°F to 70°F
- Temperature Stability: +/- 3°F
- Flow Rate: 26 to 35GPM
- Coolant: Water/Glycol 30% - 50%
- Reservoir Volume: 65 Gallons
- Connection Size: 2" Female NPT
- Electrical Service: 460V/3PH/60Hz
- Voltage Tolerance: +/- 10%
- Full Load Amps: 113A
- Min. Circuit Ampacity: 118A
- Max. Overcurrent Protection: 125A
- Short Circuit Current Rating: 10kA
- Sound Levels (+/- 2dBA): 3 meter 80dB
- Dry Weight: 3,500lbs
- Operational Weight: 4,000lbs
- Dimensions (WxDxH): 100.0" (108.8" ebox) x 44.6" x 92.6"

100kW
 4.4°C to 21.1°C
 +/-1.67°C
 98.4 to 132.4 LPM
 246 Liters

1,588kg
 1,814kg
 2581mm (2807mm ebox) x 1179mm x 2321mm

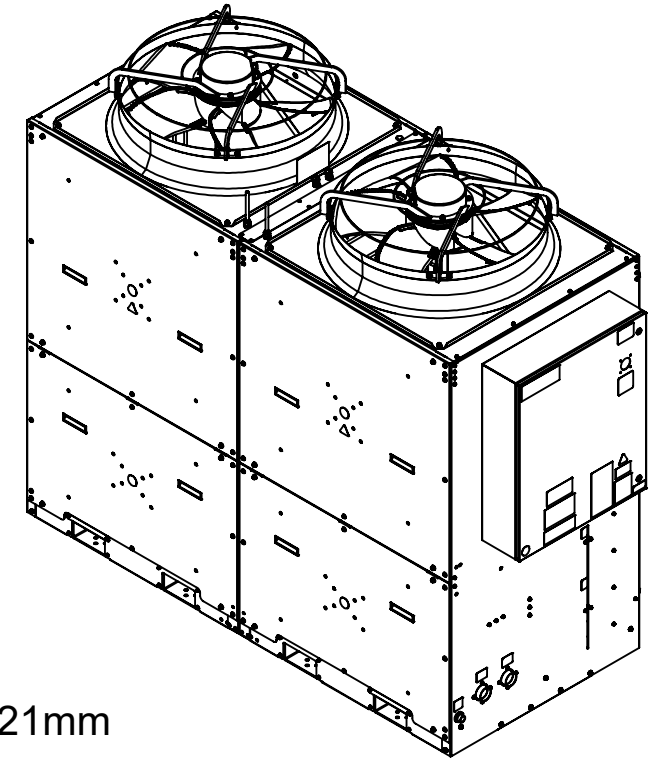

Ambient Air Conditions

- Temperature Range: -40°F to +122°F
- Air Discharge: Vertical

-40°C to +50°C

Certifications:

- UL 60335
- Seismic OSP-0867

PUMP CURVE (WATER)

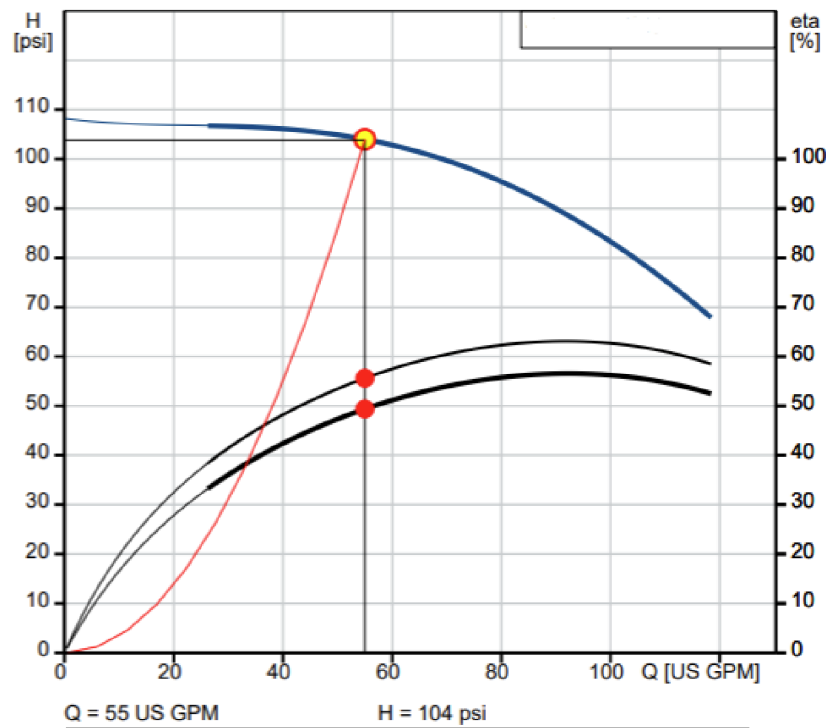

Features:

- Remote Display
- IOT (Cloud Connectivity)
- Coastal Protection:
 - Coil: 1000+Hrs Salt Spray ASTMB117
 - Powder Coated Sheet Metal
- Cleanable Air Filters with Metal Frames
- Redundant Refrigeration, Pumps, and Control System
- Adjustable Outlet Flow Control Valve
- Flow Switch for "no flow" detection.
- 100% Functional Test
- Low Tank Level Detection (Protects Pumps)
- Multi-Level Refrigeration without Hot Gas for better efficiency.
- Main disconnect w/ lockout/tagout.
- Wye Strainer for Fluid Filtration.

